

# ASCO Avtron 2700 Load Bank

**The ASCO Model 2700 (formerly Avtron LPH100) Load Bank is designed for operation indoors when up to 100 kW of resistive load is required.**



The ASCO Avtron 2700 load bank (part of the 2000 series portable product range) features the most comprehensive innovations in both design and technology.

## Load Bank Ratings

Select from standard three phase voltage ratings of:

- 100kW at 480-60 Hz, 5kW load step and 93.75kW at 240-60Hz, 3.75kW load step
- 80 kW at 400-50Hz, 5kW load step

Select from standard three phase voltage ratings of:

- 208-60Hz
- 240/480-60Hz
- 400-50Hz
- 600-60Hz

DC versions are available with typical voltage ratings of:

- 28, 48, 60, 120, 160, 270 and 400VDC

Please consult factory for non-standard ratings.

## Fan and Control Power

An external 120V, 1 Phase, 60 Hz, 5 amp power source is required for the fan and control circuits. This power is derived from the control power receptacle located on the back of the unit.

## Cooling System

Approximately 2,000 CFM cooling is provided by four (4) integral cooling fans. The cooling fans are fuse protected.

## Operator Controls

Digital monitoring via full digital metering (V, A, Hz, kW) with automated data acquisition and real time data logging, software IrDA converter supplied.

Local control panel including: Main Power ON-OFF switch, Power ON indicator, Over-temperature indicator, Load Voltage selector switch for operation at 240 or 480 volts, and Master Load ON-OFF switch. Load selection is provided by individual industrial lever-type toggle switches.

## Construction

The 2700 is constructed using heavy gauge aluminized steel per ASTM A463. It is designed for continuous indoor operation.

Two (2) moveable and two (2) fixed casters are provided for easy mobility. Handles are provided for lifting the load bank when it is being transported.

All exterior fasteners are stainless steel.

## Finish

The 2700 has a high quality baked polyester powder coated finish with a film thickness of 2.8 +/- 0.4 mils per coat. The standard color is gray (ANSI 61).

## Two Year Warranty Included

The equipment is covered by an industry exclusive 24-month parts and labor warranty.

**ASCO**®

**For more information on the 2700 or any other 2000 SERIES load bank please contact a member of our sales team at [customer@ascopower.com](mailto:customer@ascopower.com) or 216-573-7600.**

## Resistor Elements

The ASCO Avtron brand load banks use helically wound chromium alloy Helidyne elements. Elements are supported by ceramic insulators on internal frame supports. These elements are designed to operate at approximately 1/2 of their maximum continuous wire rating.

Elements are positioned within the cooling airstream for optimal performance. Changes in resistance due to temperature are minimized by maintaining conservative watt densities.

The overall load tolerance of the 2700 load bank is -0, +5%. This ensures that advertised kW is delivered at rated voltage.

The elements are continuously rated at the specific voltage. Tests at lower voltages, with a corresponding reduction in overall rating, may be carried out.

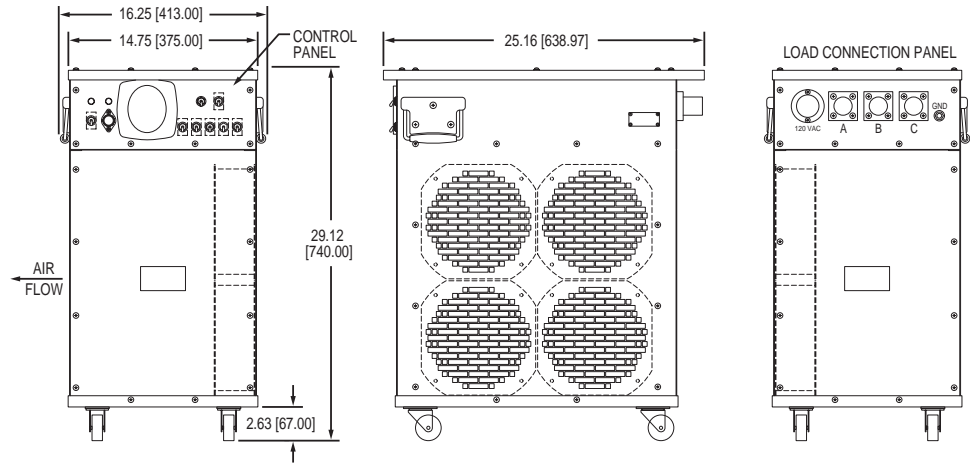

## Safety Features

Exhaust temperature sensors are provided to monitor the flow of cooling air. These switches are electrically interlocked with the load application. If the fans are not working properly, the load steps are disabled.

The load bank also contains fuses for short circuit protection. The control circuit is protected with a 5 amp fuse while the voltage signals to the meter are protected with 1 amp fuses. The load circuit is protected with three main line fuses (one per phase).

## Ambient Temperature and Humidity

The 2700 load bank is designed for continuous duty cycle with no limitations. The ambient temperatures range is -20°F to 120°F (-28°C to 50°C).

All dimensions are in inches [millimeters].  
Specifications subject to change without notice.

## Environment

The 2700 is self-contained portable load bank designed for operation and storage indoors.

## Power Terminals

Input connections are quick connect style receptacles mounted on the front of the load bank.

## Optional Accessories

- Heavy Duty Transport Case
- 20' Load Cable Set with Connectors

## Documentation - Operating Manual

A comprehensive operator's manual is supplied electronically via a USB drive.

Sections include: Safety, Installation, Operation, Maintenance, and Troubleshooting.

## Testing and Standards

The ASCO Avtron brand load banks comply with NEMA, NEC, and ANSI standards. Quality control system is certified to ISO9001 standards.

## Weight and Dimensions

Dimensions (approx. in/mm)			Weight (approx. lb/kg)
Length	Width	Height	
25/639	16.25/413	29/740	105/48



2700 heavy duty transport case.



2700 shown with DC metering controls.